

### Professional Series

#### Key Features:

- ▶ Stylish, unobtrusive design fits into a wide variety of decors
- ▶ High fidelity sound
- ▶ Selectable 70V/100V for distributed lines, or low impedance
- ▶ Versatility for either two or four satellite speakers per system
- ▶ Ability to mix and match with Control Contractor 40 Series in-ceiling models
- ▶ Wall-mount brackets included
- ▶ Available in black or white

The Control 50 Series subwoofer-satellite loudspeaker system provides high fidelity sound in restaurants, retail stores, music cafes, health clubs, theme bars, leisure venues, or any location where full-range high fidelity foreground/background music is required from surface-mount system.

#### Control 52 Satellite Speaker

The stylish Control 52 satellite loudspeaker produces superb high fidelity sound via a low-distortion 60 mm (2½ in) driver, which features a secondary bucking magnet for high efficiency, rubber half roll surround for enhanced bass performance, 19 mm (0.75 in) copper clad aluminum wire voice coil on a vented Nomex® former for high fidelity and reliability, and a copper-capped pole piece for more consistent impedance and extended high frequency response. The wall bracket allows each speaker to be angled up to 45° off-axis.



#### Control 50 Subwoofer

The 150 Watt (600 Watt peak) Control 50S/T subwoofer contains a high-power, long-excursion, 200 mm (8 inch) driver which features an extremely robust high-mass cone for extended low frequency response, a 38 mm (1.5 in) 4-layer copper voice coil for high motor strength, an aluminum former for good transient response, and a rubber half roll surround for enhanced bass performance. The Control 50S/T's included two-piece easy-mount wall-bracket installs quickly: The multi-point wall portion of the bracket attached to the wall and the self-guiding speaker-mounted bracket drops into place for a secure attachment. A cover over the Control 50S/T terminal cup keeps wiring neat. The Control 50S/T is mono. The crossover network built into the subwoofer provides proper signal routing and four satellite output connectors allow connection of the wires for the four Control 52 satellite loudspeakers. A Loop Out connector is also provided on the subwoofer for looping the full-range input signal to other loudspeakers or to other subwoofer/satellite systems.

#### System Configuration

Available as packaged system or as separate items, the Control 50 Series is extremely versatile system. The C50PACK system contains four Control 52 satellite speakers and one Control 50S/T subwoofer as an easy predesigned system. For smaller floor spaces, the Control 50S/T subwoofer can be utilized with two Control 52 satellite speakers. The Control 50 system is mono. Both the Control 50S/T and Control 52 can be intermixed in systems along with the Control 40 Series in-ceiling models – Control 40CS/T subwoofer and Control 42 satellite speaker – to match the form factor requirements of a wide variety of applications.

# ► Control 50S/T and Control 52 Surface-Mount Subwoofer-Satellite Loudspeaker System

## Control 50 Subwoofer-Satellite System Specifications

Frequency Range (-10 dB) <sup>1</sup> :	32 Hz – 20 kHz
Frequency Response (±3 dB) <sup>1</sup> :	50 Hz – 17 kHz
Power Capacity <sup>2</sup> :	200 Watts Continuous Program Power (100 hrs) 100 Watts Continuous Pink Noise (100 hrs)
Nominal Sensitivity (2.83V, 1m) <sup>1</sup> :	87 dB with 4 satellites 85 dB with 2 satellites (subwoofer center of wall, higher sensitivity depending on subwoofer boundary loading, see application note)
Nominal Impedance:	4 ohms (in bypass/thru mode) with 4 satellites 8 ohms (in bypass/thru mode) with 2 satellites
Transformer Taps:	80W, 40W, 20W, (& 10W @ 70V), plus bypass/thru (listed as 8Ω on switch to indicate subwoofer impedance)

## Control 50S/T Specifications

Frequency Range (-10 dB) <sup>1</sup> :	32 Hz – 200 Hz
Frequency Response (±3 dB) <sup>1</sup> :	50 Hz – 150 Hz
Power Capacity <sup>2</sup> :	300 Watts Continuous Program Power (2 hrs) 150 Watts Continuous Pink Noise (2 hrs) 200 Watts Continuous Program Power (100 hrs) 100 Watts Continuous Pink Noise (100 hrs)
Nominal Sensitivity (2.83V, 1m) <sup>1</sup> :	95 dB (near corner), 89 dB (center of wall)
Rated Maximum SPL (1m):	115 dB average, 121 dB peak (near corner) 109 dB average, 115 dB peak (center of wall)
Nominal Impedance:	8 ohms (in bypass/thru mode)
Transformer Taps:	80W, 40W, 20W, (& 10W @ 70V), 8 ohm bypass/thru

### Transducer:

Driver: 200 mm (8 in) with polypropylene cone, butyl rubber surround, 38 mm (1.5 in) 4-layer copper-clad coil, vented aluminum former

### Enclosure:

Input Connectors: Six removable locking 2-pin connectors with screw-down terminals. Max wire 12 AWG (2.5 mm<sup>2</sup>)

Material: Top, bottom, front & bottom: Structural plywood. Port & terminal panels: MDF. Grille: Painted zinc-plated metal.

Dimensions (H x W x D): Cabinet: 356 x 391 x 203 mm (14.0 x 15.4 x 8.0 in)  
Wall Bracket: 15 mm (0.6 in) deep

Wall Bracket: 2.3 mm (0.9 in) thick zinc-plated and painted cold-rolled steel

Net Weight: 9.0 kg (20 lbs)

Shipping Weight: 10.2 kg (23 lbs)

Included Accessories: Wall bracket (both speaker and wall parts) with 4 pcs M6 screws to attach to speaker, terminal cover, 6 pcs 2-pin locking connectors, M6 screw for safety lanyard attachment.

## Control 52 Specifications

Frequency Range (-10 dB) <sup>1</sup> :	140 Hz – 20 kHz
Frequency Response (±3 dB) <sup>1</sup> :	180 Hz – 17 kHz
Power Capacity <sup>2</sup> :	50 Watts Continuous Program Power (2 hrs) 25 Watts Continuous Pink Noise (2 hrs) 30 Watts Continuous Program Power (100 hrs) 15 Watts Continuous Pink Noise (100 hrs)
Nominal Sensitivity <sup>1</sup> :	85 dB (4.0V/1m = 1W) 82 dB (2.83V, 1m)
Nominal Coverage Angle <sup>3</sup> :	150° x 150° (omnidirectional)
Rated Maximum SPL (1m):	94 dB average, 100 dB peak
Nominal Impedance:	16 ohms

### Transducer:

Driver: 60 mm (2.5 in) with polypropylene cone, butyl rubber surround, 19 mm (0.75 in) copper-clad coil, vented Nomex<sup>®</sup> former, secondary bucking magnet, and copper sleeved pole piece for high frequency extension.

### Enclosure:

Input Connector: Removable locking 2-pin connector with screw-down terminals. Max wire 12 AWG (2.5 mm<sup>2</sup>)

Material: High impact polystyrene, painted zinc-plated metal grille.

Dimensions (H x W x D): Cabinet: 115 x 84 x 96 mm (4.5 x 3.3 x 3.75 in)  
Wall bracket: 51 mm (2.0 in)

Net Weight: 0.7 kg (1.5 lbs)

Shipping Weight: 0.8 kg (1.8 lbs)

Included Accessories: Wall bracket (both speaker and wall parts), 2-pin locking connector.

<sup>1</sup>Half-space (mounted on wall).

<sup>2</sup>Continuous Pink noise rating is IEC-shaped pink noise with a 6 dB crest factor for 100 hours continuously. Continuous Program Power is a conservative expression of the system's ability to handle normal speech and music program material, and is defined as 3 dB above the Continuous Pink Noise rating.

<sup>3</sup>Half-space, average 1 kHz – 4 kHz

**Control 52 Dimensions:**  
Dimensions shown in mm (in)

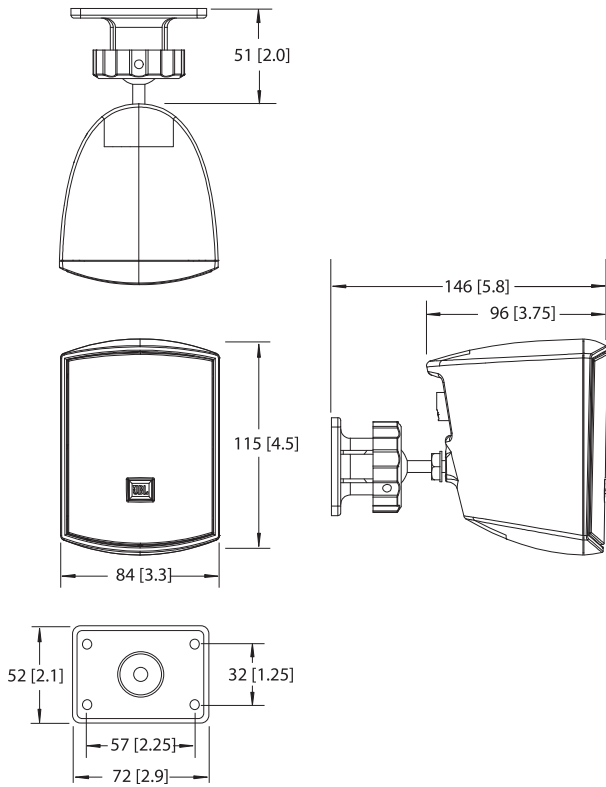

**Control 50S/T On-Wall Bracket Dimensions:**

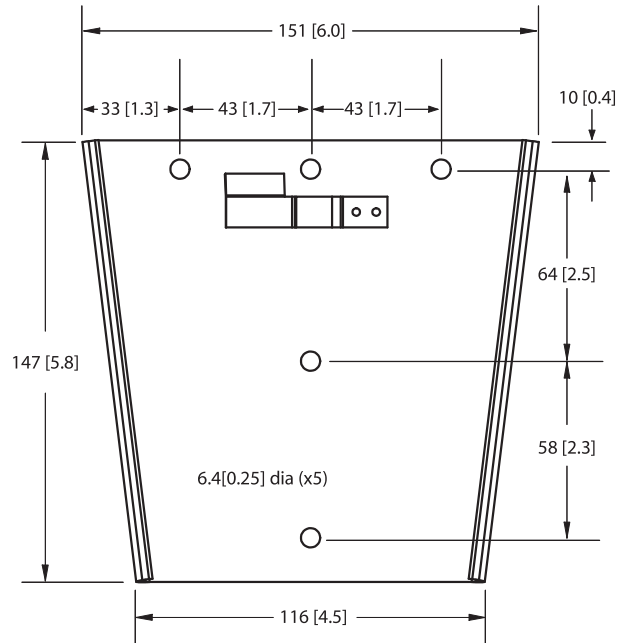

**Control 50S/T Dimensions:**  
(Shown with wall bracket)  
Dimensions shown in mm (in)

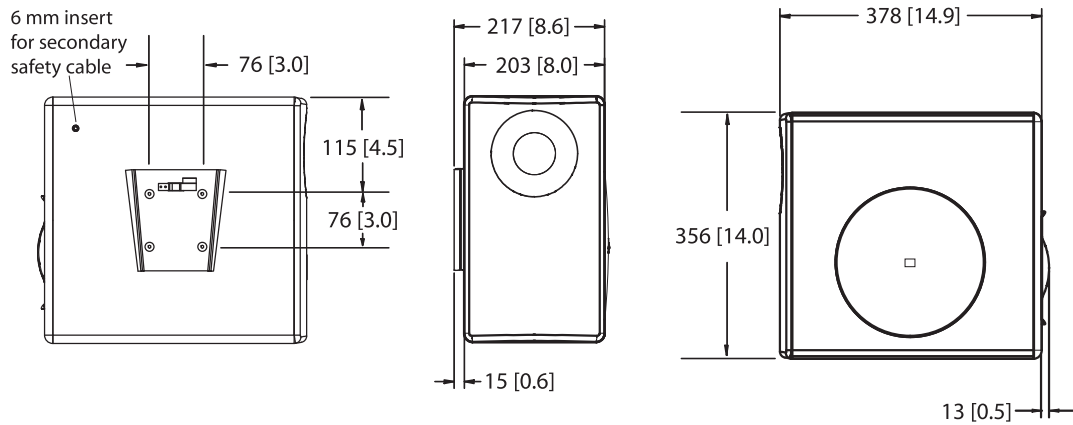

## ► Control 50S/T and 52 Surface-Mount Subwoofer-Satellite Loudspeaker System

### Frequency Response:

Half-Space ( $2\pi$ , subwoofer & satellites mounted on wall)

Response of each model shown separately.

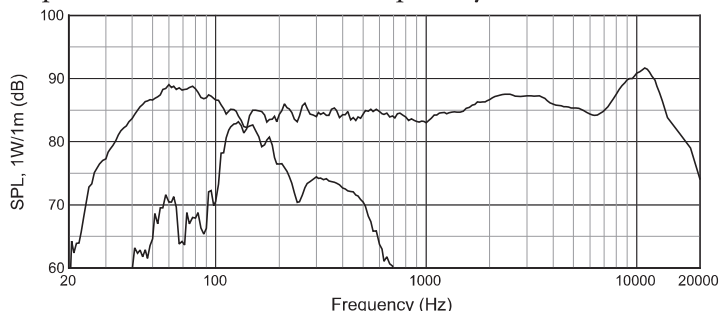

### Subwoofer-Satellite Input / Output Termination:

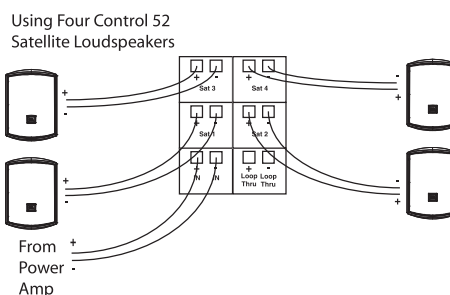
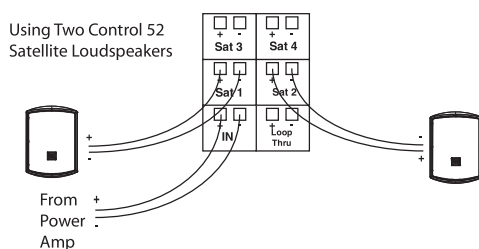

### Application Notes:

**Subwoofer Placement for Tonal Balance** – The location of the subwoofer in relation to wall, floor or ceiling affects the tonal balance of the system. In systems having two satellite speakers, proper balance of sound is usually best attained by installing the subwoofer via its wall-mount bracket at the center of a wall (instead of mounting it at a 2-boundary area such as a wall-floor junction). For systems with four satellite speakers – such as the Control 50PACK System – mounting the subwoofer in the center of a wall produces good basic bass levels. Locating the subwoofer at a two-boundary junction, such as a wall-floor or wall-wall junction, provides stronger bass. A corner location provides the strongest bass for maximum bass impact. In addition to subwoofer placement, external electronics equalization such as from tone controls or DSP can be utilized to adjust the tonal balance further.

**Port Clearance** – Do not block the port of the Control 50S/T subwoofer by mounting too close to a side wall. Leave a minimum of 50 cm (2 feet) of clearance between the port and an adjacent wall surface.

**Using Control 52 without Control 50S/T Subwoofer** – The Control 52 can be damaged if driven with frequencies below 140 Hz. The subwoofer provides the proper high-pass filter. For using Control 52 by itself (not driven from the Control 50S/T's satellite output), the signal must be high-passed, either via a passive high-pass built into another subwoofer such as the JBL Control 40CS/T in-ceiling subwoofer, or via an electronic high-pass, electronic crossover, or DSP (140 Hz, 24 dB/oct recommended). Failing to high-pass the Control 52 can result in damage to the speaker.

**Wall Bracket Orientation** – Install the wall bracket so that the subwoofer drops down into the bracket. The bracket clicks into place. Do not install the bracket sideways or on a ceiling. See the Control 50S/T Installation Guide. To remove the subwoofer, release clip by pushing clip toward subwoofer with long screwdriver (or similar) from the top side of bracket.

**Secondary Safety Cable** – When installing subwoofer, always utilize a secondary safety cable attached to the separate 6 mm insert located on the back/wall side of the subwoofer.



JBL Professional  
8500 Balboa Boulevard, P.O. Box 2200  
Northridge, California 91329 U.S.A.

■ A Harman International Company  
© Copyright 2009 JBL Professional  
[www.jblpro.com](http://www.jblpro.com)

SS Control 50  
CRP  
06/09